

Research and Production Company  
"Machinery and Tools  
Engineering Group" LLC

**NPO "GKMP" LLC**

**MAKING YOUR IDEAS  
COME TRUE!**



**THERMAL VACUUM  
TECHNOLOGICAL  
FACILITIES**



**GKMP**  
RESEARCH & PRODUCTION  
COMPANY

# ABOUT COMPANY



The “NPO “GKMP” LLC became the flagship of scientific, experimental and production industries in Russia. The hardware designed for thermal nuclear fusion, cryogenic and thermal vacuum hardware for testing reached a substantially new level.

Our experimental set-ups are unmatched and serially produced hardware meets the highest international standards.

Our company’s frontline products are successfully used for more than 10 years by the top advanced manufacturers of our country. Making big ideas come true, our experts are capable to complete the most challenging research and development projects.

Today the “NPO “GKMP” is a leader in research of natural and technical science.



## **FROM CONCEPTION TO SOLUTION**

The “Research and Production company” Machinery and Tools Engineering Group” LLC is the Russian developer and manufacturer of special-purpose industrial equipment, high temperature gas and vacuum electric furnaces of different design and application, technological lines for thermal treatment, quenching, annealing and tempering of complex shape and size pieces, vacuum sputtering machines, thermal diffusion, thermal compression machines, machines for monocrystal growing, test benches, thermal vacuum chambers, vacuum shutoffs and other high-tech hardware.

Quality management system of the “NPO “GKMP” LLC is certified in accordance with requirements of the standard GOST R ISO 9001-2015 and confirmed by the respective conformity certificates. The “NPO “GKMP” LLC successfully completes audit checks on yearly basis. Moreover, the company is subject to regular internal audits of the quality management systems.

The company managed to gather the best specialists in their fields of expertise. Many years of experience accumulated by few generations of engineers and technicians along with workmanship of employees and proper management enabled to create a world-renowned production company. The contracts successfully completed for the last few years contribute to the ability of the company’s team to tackle any challenges.

## **TOGETHER TOWARDS SUCCESS**

The long-term cooperation with various companies engaged in electronic, nuclear and aerospace industry ensures our company’s sustainable growth and mastery over new products and hardware. Well-developed production standards, as well as client targeted policy put our company among leaders at the domestic market.

The hardware produced by our company operates at the most challenging sites of nuclear and electronic industry. As of this moment, our company is the only domestic manufacturer with a full production cycle of machines designed for vacuum sputtering, thermal diffusion and thermal compression facilities; our vacuum chambers are officially renowned as the best among domestically produced facilities.

Over the years the company earned several local and federal awards.

## **OUR MISSION**

By making ideas come true our experts are capable to put into life the most complex scientific and research works. Our production capacities enable us to create hardware with completely unique characteristics.

**We are the best and always move on!**

# THE FULL SCOPE OF SERVICES



## In-the-house production

The company's production site is subject to scheduled upgrade with a specific emphasis on system improvement and equipment. Over 250 machines are equipped with up-to-date tools.



## Comprehensive solutions

We provide the entire scope of services aimed at development from conception to construction, mounting activities and commissioning.



## Well-aligned staff

There are over 750 employees that represent the team of highly qualified experts in the field of comprehensive engineering, as well as efficient management and project management. There are more than 110 employees engaged in engineering.

**QUALITY ASSURANCE**

## Quality assurance

Expanded guarantee for machines produced, as well as post-warranty maintenance.



## Certificates and permissions

Any permission documents and certificates are available.

## WE KNOW HOW TO MAKE YOUR PROJECT BETTER!

- Engineering, design, specification drawing up, calculations;
- Manufacture;
- Delivery;
- Mounting, supervised mounting;
- Training of customer's specialists;
- Test;
- Warranty, post-warranty maintenance;
- Disposal.

## The “NPO “GKMP” LLC provides a wide range of services for metal and piece treatment:

- Preparatory operations – gas oxygen cuttings, plasma cutting, hydro abrasive cutting,
- guillotine shear cutting, bending, casting etc.;
- Any mechanical machining – lathe, milling, gear machining, planing, polishing;
- Manual and mechanized welding;
- Thermal treatment – gas cementing, release, annealing, tempering, high-frequency brazing etc.;
- Additional services on painting and shot blasting.

## PRODUCT LINES OF THE “NPO “GKMP” LLC:

- Vacuum shut-offs, pumping systems and customized technical hardware;
- Test vacuum benches and facilities;
- Industrial thermal equipment;
- Crystal growing machines;
- Coils for electromagnetic systems;
- Stainless steel metal bellows;
- Parts from refractory metals and alloys;
- Road construction machinery;
- Magnetic systems and elements for large-scale magnetic system;
- Spare parts for vacuum and thermal hardware.

## OUR PARTNERS:



We are awarded by industrial leaders  
You are welcome to join our team!



## OVER 75 SUCCESSFUL PROJECTS OF THE FOLLOWING INDUSTRIES:

- Metallurgy
- Aerospace
- Machinery
- Energy
- Electronics
- Additive technologies
- Nuclear industry



## PRODUCTION CAPACITIES



- Internal production site and design bureau;
- Finished goods warehouse, 2 raw materials warehouses and open-air storage sites;
- 4 administrative buildings;
- Vacuum laboratory;
- Non-destructive control laboratory with ultrasonic system based on phased array technology (experimentally proven quality of welded seams on 300 mm thick stainless steel) and X-ray laboratory;
- 1700 m2 clean room, cleanliness class 8;
- Final assembly lines and sites;
- Tensile machine.



### Basic hardware:

- Rolls;
- Milling machines;
- Hydraulic presses;
- Cranes;
- Overhead cranes;
- Sheet bending machines;
- Profile bending machines;
- Automatic welding hardware;
- Thermal cutting machines for plasma or gas metal sheet cutting;
- Braiding material;
- Other special-purpose industrial hardware to enable high quality and output etc.



Industrial solutions that require precision are carried out using **the high-tech CNC machines.**



**GKMP**  
RESEARCH & PRODUCTION  
COMPANY

**2010**

Foundation of the Company

**2012**

Close cooperation with scientific centers of the industry

**2013**

Creation of experimental facility in order to study controlled thermonuclear fusion

**2015**

Establishment of the Moscow headquarters

**2016**

The "Irmash" LLC is merged with the "NPO "GKMP" LLC. In May 2016 "Irmash" LLC, a leading Russian manufacturer of road building and excavating machines is merged with the "NPO "GKMP" LLC

**OUR CUSTOMER'S PORTFOLIO IS OUR OUTSTANDING LANDMARK!**



радиолокация  
технологии  
информация

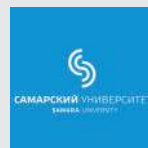

ФЕДЕРАЛЬНОЕ ГОСУДАРСТВЕННОЕ УНИТАРНОЕ ПРЕДПРИЯТИЕ  
«ГОРНО-ХИМИЧЕСКИЙ КОМБИНАТ»  
ПРЕДПРИЯТИЕ ГОСКОРПОРАЦИИ «РОСАТОМ»



# BACKGROUND

## 2017-2019

Development and manufacture of hardware designed for nuclear fusion. High-tech machinery becomes the new emphasis

## 2020

The company joined the ITER project aimed at creation of the international thermonuclear reactor

## 2022

Design and manufacture of the facility to imitate space environment (thermal vacuum facility) and solar radiation simulators

## 2023

The "NPO "GKMP" LLC just as we start cooperation, we are aimed at building a long-term relationship with the Customer and always willing to improve the existing solution and create new ones in response to the growing needs of the Customer.

Just as we start cooperation, we are aimed at building a long-term relationship with the Customer and always willing to improve the existing solution and create a new one in response to the growing needs of the Customer.

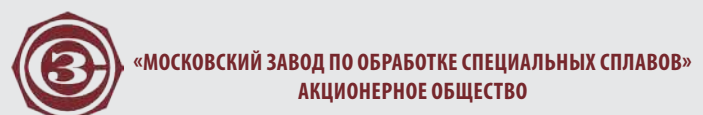
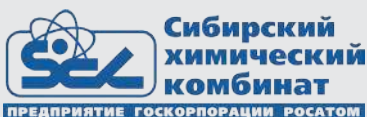

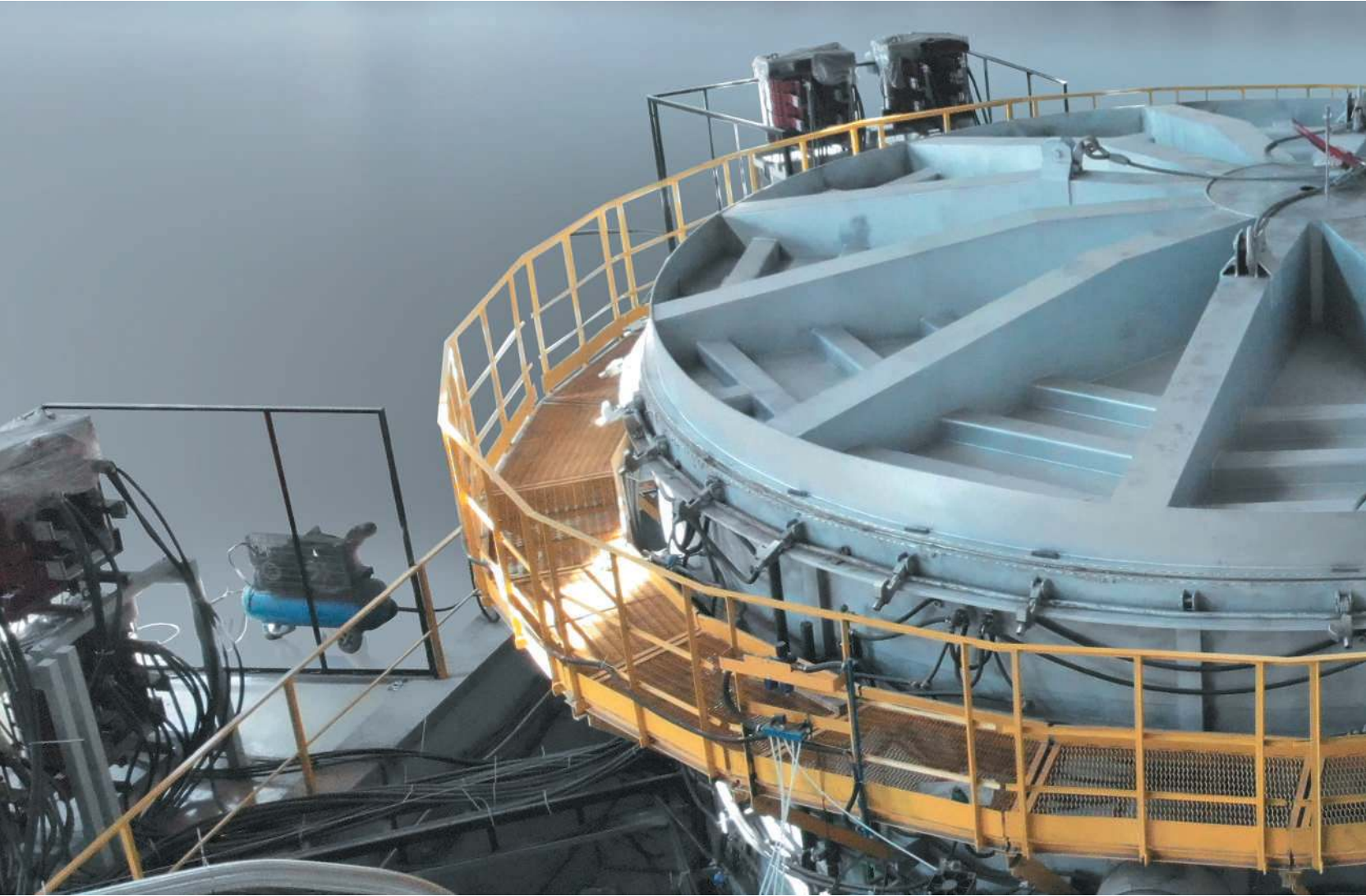

**Vacuum chambers and facilities** are systems that incorporate few vacuum pumps designed to create high technical vacuum inside the system, thus being up to be involved in variety of applications. Such facilities are often operating exclusively at high vacuum. These facilities can be used almost in any industry, starting from small stationary systems to large factories.

We address complex issues related to design, production and implementation of special-purpose systems.



#### **We produce:**

- Vacuum chambers;
- Vacuum fittings;
- Vacuum pumps;
- Vacuum furnaces;
- Vacuum filters;
- Vacuum systems;
- Vacuum pipelines;
- Different compressors;
- Test facilities;
- Thermal compression facilities;
- Test benches and facilities;
- Vacuum sputtering machines;
- Thermal special purpose vacuum facilities.



## CONTENT

About company	2
Thermal vacuum technological facilities	12
Destructive and non-destructive control laboratory	14
Thermal vacuum test facility for space environment simulation TVACF-2	16
Vacuum shaft resistance furnace	18
Tokamak T-15MD	20
Thermal vacuum chamber TVC-110	24
Vacuum facility for qualification of high-power pulsed hydrogen plasma thrusters	26
ITER Port plug test facility	28
Cryogenic vacuum facility VU-180	30
Vacuum chamber section	32
Facility for testing of stationary plasma thrusters for 1.P5C (India)	33
Carbothermal synthesis facility (CSF)	34
High vacuum rectangular chamber for fundamental research	35
Thermal vacuum test facility	36
Automatic control systems for vacuum hardware and special-purpose equipment	38
Cryogenic tanks	39

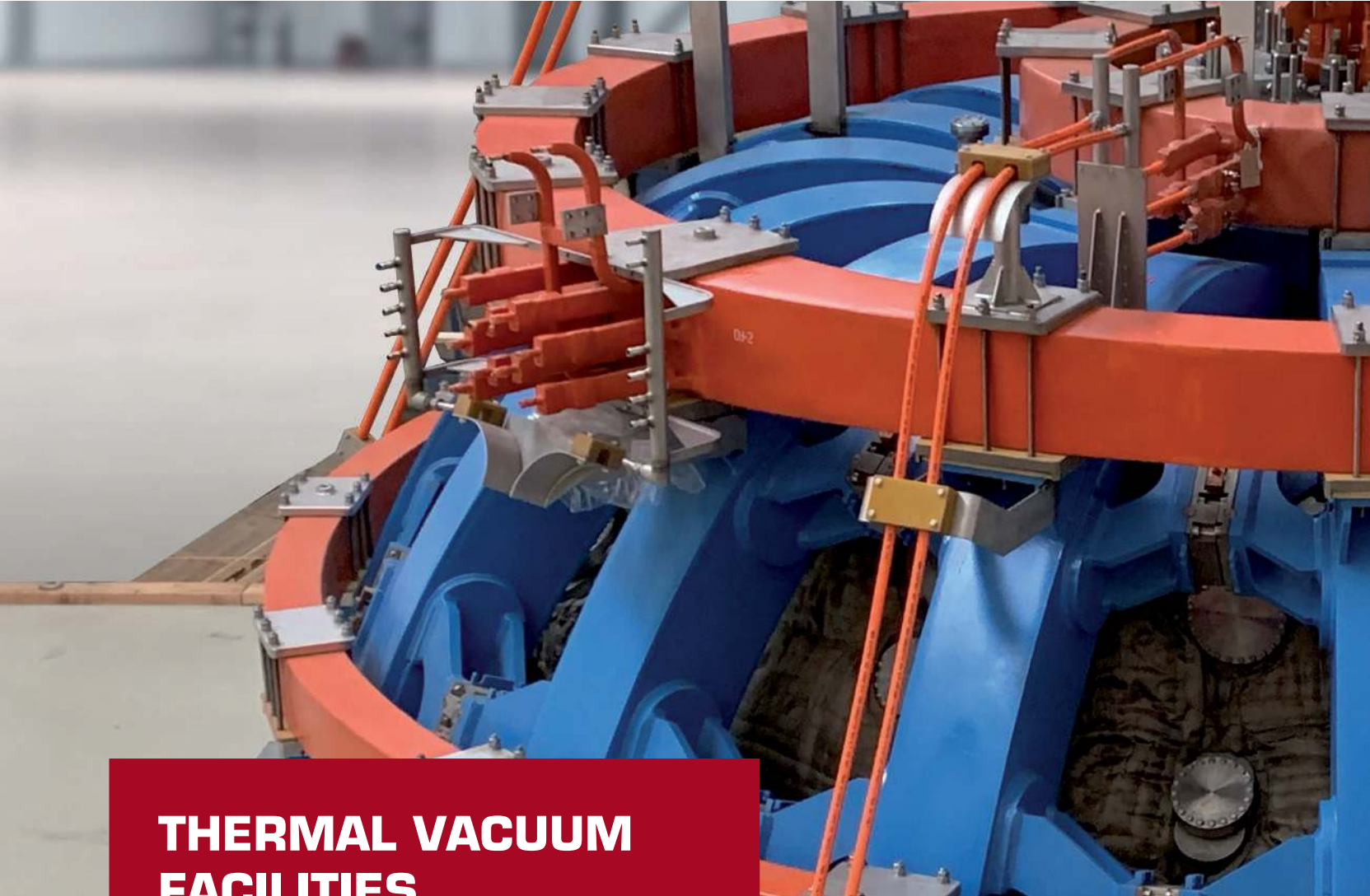

## THERMAL VACUUM FACILITIES

The “NPO “GKMP” designs high-tech vacuum facilities and customized vacuum hardware. Thermal vacuum technological facilities are used for thermal testing and qualification of technological processes in vacuum.

Thermal technological benches and facilities have to comply with high quality requirements, as well as to those applied to operational stability either in manual or in automatized mode. To qualify assembly units, nodes and technological units, a comprehensive operational testing shall be performed in conditions representative to the real ones.

The “NPO “GKMP” has a vast experience in cooperation with the leading companies of the Russian Federation interested in using thermal vacuum technologies and facilities in their internal technological processes. As long as such facilities are one-of-the-kind for each client and respectively customized, we consequently employ individual approach, starting from the specification drawn-up, basic calculations and technical project, where we discuss with Customer’s experts all ins and outs of technical performances that a research facility shall have; apart from that, the operational design documentation is prepared, and a brand new item is produced. The outstanding expertise, technical and technological backlog in design and warranty maintenance of these facilities enable the “NPO “GKMP” LLC to tackle any and successfully deal with any issue.



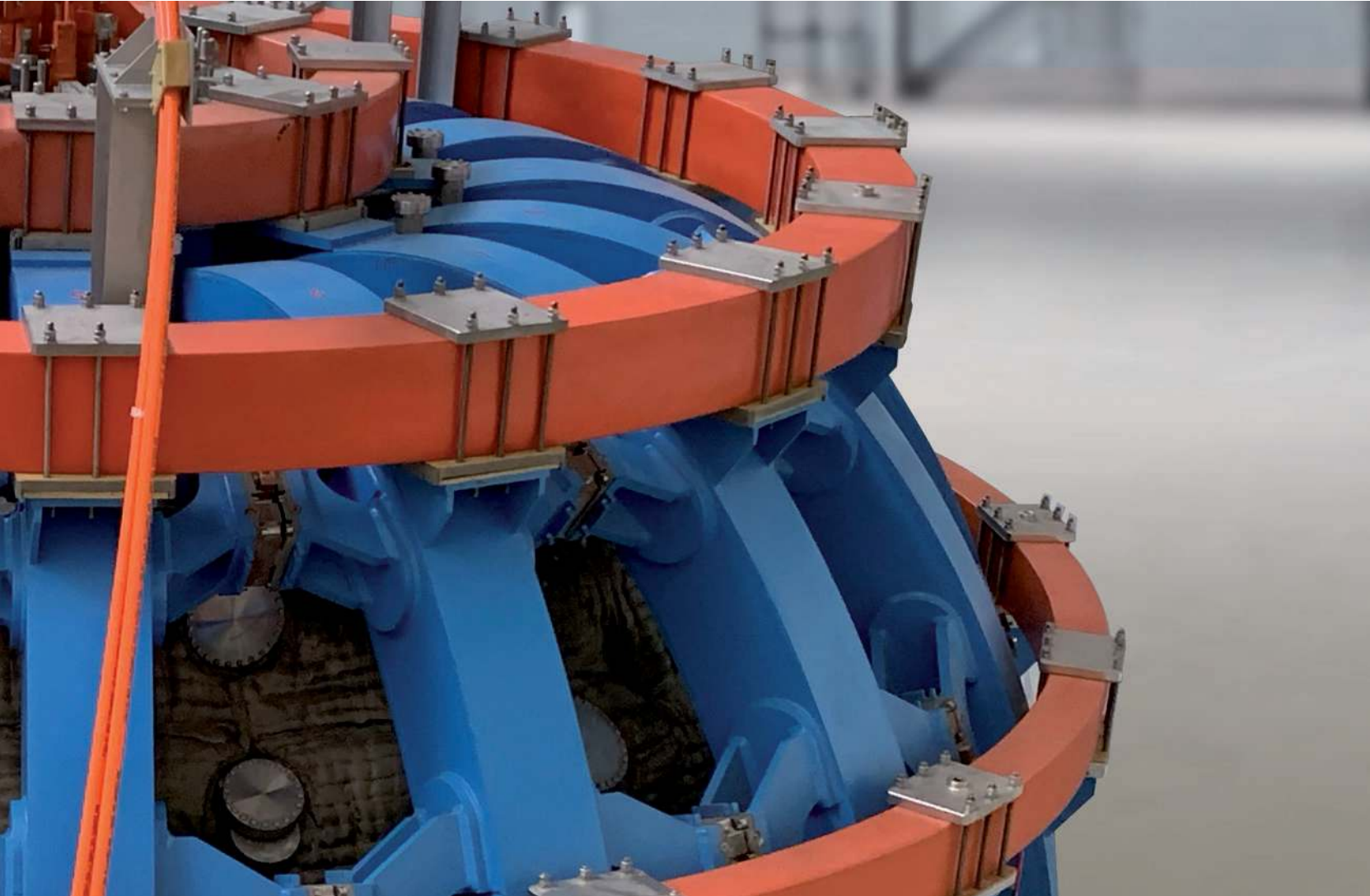

Vacuum hardware is produced with the help of the cutting-age materials that provide the maximal lifetime to the unit.



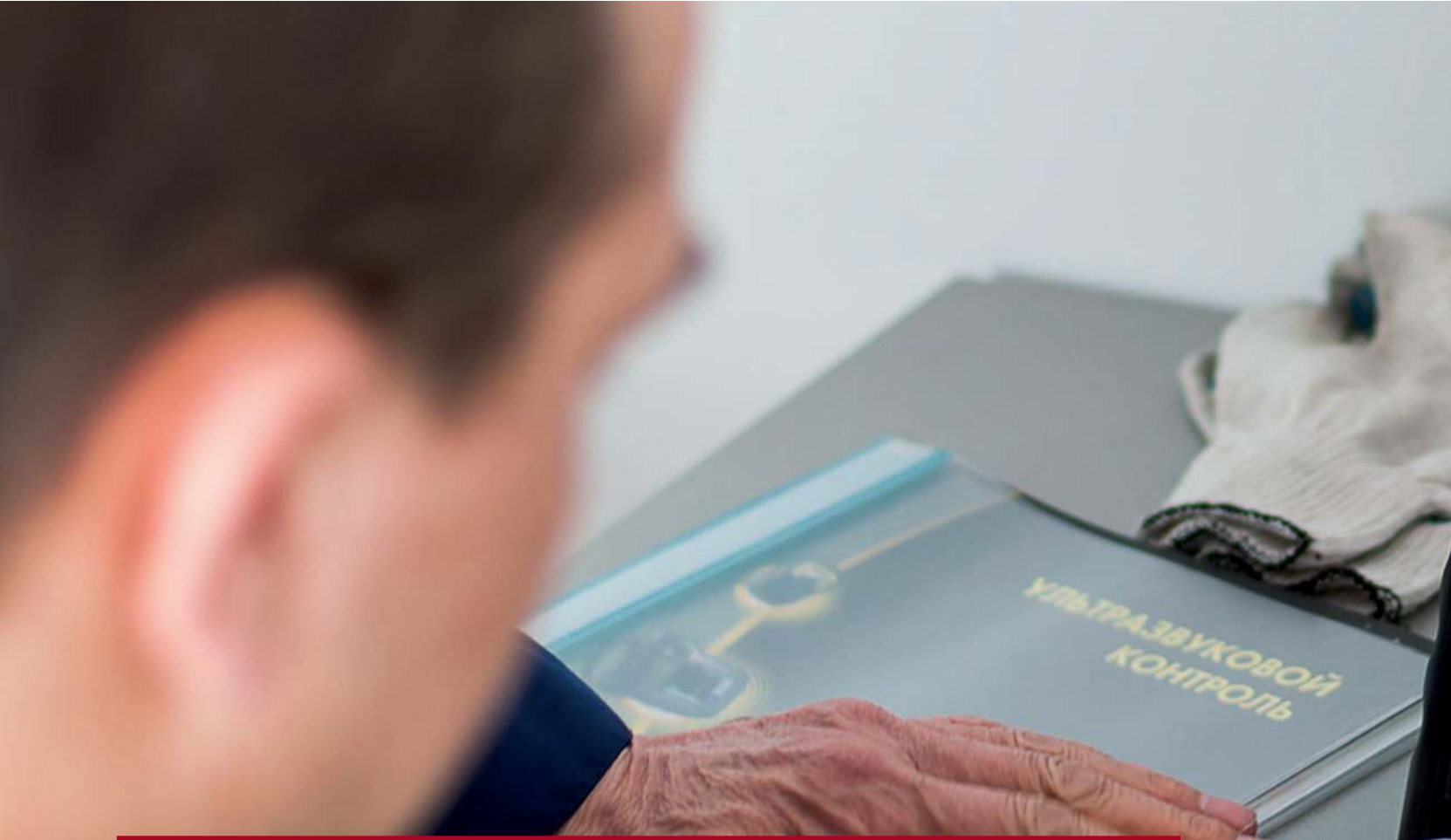

# LABORATORY FOR DESTRUCTIVE AND NON-DESTRUCTIVE CONTROL

Production department integrated in quality assurance has a dedicated laboratory equipped with the hardware in order to perform the following quality research:

## Non-destructive control

- Ultrasonic control;
- Mass-spectrometer control;
- Radiography;
- Penetrant inspection;
- Visual inspection and measurements.



Computer radiographic hardware "Phosphomatic -40100"



Mass Spectrometer  
Leybold Phoenix Quadro Dry



### Laboratory test

- To define mechanical properties of a given material and welded seams (strength, yield, elongation and contraction, impact viscosity, hardness);
- To define chemical composition of metals, metal type used and welding wire by using X-ray fluorescent and spectral analysis;
- Metallographic inspection of metals and welded seams.

Welded seams are subject to the X-ray inspection. The vacuum density of welded seams is checked via an up-to-date helium leak detector made by the leading manufacturers.

Linear and angular values, roughness, hardness, coating thickness and electrical values are inspected.



X-ray machine RPD-200

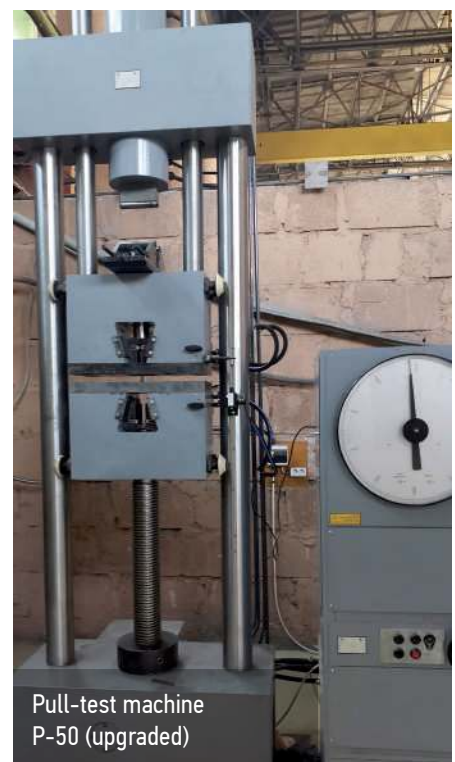

Pull-test machine P-50 (upgraded)

Quality assurance experts are certified per Rosatom system and ISO 9712.



## THERMAL VACUUM TEST FACILITY FOR SIMULATED SPACE ENVIRONMENT TVACF-2

The **TVACF-2** is intended to measure optical and physical parameters when creating and performing an on-ground qualification of on-board equipment, as well as other optical and electronic systems and facilities in simulated space environment. The effective diameter of the vacuum chamber is 5000 mm, the height is 10000 mm. Moreover, the test facilities are designed to test electric and radio components, especially microchips and discrete modules in non-standard conditions. Commonly such facilities are used to test exposure to extreme temperatures and change of pressure in order to check the opportunity to use products in industry. Depending on its purpose, the test facility can be a multifunctional system, a chamber, a bench or area. Test facilities are operated using a high-tech interface that enables to control the process and keep the test results recorded by the computer at the same time.

The thermal vacuum chamber consists of separate sections manufactured from corrosion resistant steel (AISI 3211). Its internal surfaces are polished, the roughness rate is  $Ra = 0.63 \mu m$ , the welded seams roughness is equal to  $Ra = 2.5 \mu m$ . Sections are connected by flanges with seals – elastic viton cord with additionally vacuumed space between them. TVACF is mounted on vibration isolating supports to protect the TVACF-2 facility from any other outer vibrations.

### TVACF cryogenic components:

- Vacuum chamber;
- Vacuum system;
- Cryogenic system to simulate space environment;
- Optical system to simulate point-type object radiation;
- Solar radiation simulation system;
- Thermal flux simulation system;
- High-precision hexapod to move and tilt objects.



To load and unload the equipment under test inside the vacuum chamber we have designed a loading port with sliding leak-tight gates 2500 mm wide and 3500 mm height. The port is sealed by two elastic viton cord with additionally vacuumed space between them. The vacuum system uses serially produced vacuum pumps. Space environment simulator is a system of cryogenic screens with heat-exchange units cooled down by liquid nitrogen supplied by cryogenic system.

Heat simulation of space environment is ensured by the system of cryogenic screens that pump through the liquid nitrogen with the help of gas-lift effect. The liquid nitrogen supply system includes cryogenic storage tanks, fueling nodes, cryogenic pipes with thermal blanket, as well as the liquid nitrogen separating device that ensures the coolant circulation. The optical system to simulate point-type object radiation is a two-channel cooling collimator with its components mounted on special movable supports to adjust and aim the system.

Solar radiation imitator is designed to create inside the vacuum chamber an almost parallel radiation beam with spectrum as close as possible to the extra atmospheric solar one with the cross-sectional irradiance from 1350 to 1900 W/m<sup>2</sup>.

Heat flux imitator (HFI) is to simulate heat fluxes in vacuum at cryogenic temperatures.

**HFI includes:**

- Infrared heater system of power supply units;
- Set of cables.



Other components of the TVACF-2 are managed by an automated control system. The architecture of the ACS, the associated software ensures development and upgrade of the control system by the user while operation by changing the hardware, devices, module and software configuration.

**Technical specifications:**

Residual operating pressure inside the vacuum chamber	1x10 <sup>-4</sup> Pa
Pumping device type	Oil-free
Average temperature of the IR cryogenic screen	(85±5) K
Specific thermal capacity of the test facility adjusted within range	from 1350 to 1900 W/m <sup>2</sup>
TF Light flux homogeneity	15 %
TF Main reflector temperature	from 253K to 273K
FU axis slide in two mutually perpendicular directions	from 0° to ±12°
Rotation around FU vertical axis	±185°
FU lifting capacity	1500 kg
Dimensions of objects mounted on FU (WxLxH)	2000x2000x3500 mm
FU drive temperature	+40°C
FU Thermal flux density within the infrared band	from 0 to 500 W/m <sup>2</sup>
FU thermal flux homogeneity per irradiated surface	15%
HFI irradiation area on the object surface	90°±10°
Dimensions, m:	
Diameter of the thermal vacuum chamber (no connection pipes) (m)	5.3
Height of the vacuum chamber (m)	10.0
Internal diameter of the thermal vacuum chamber (m)	5.0

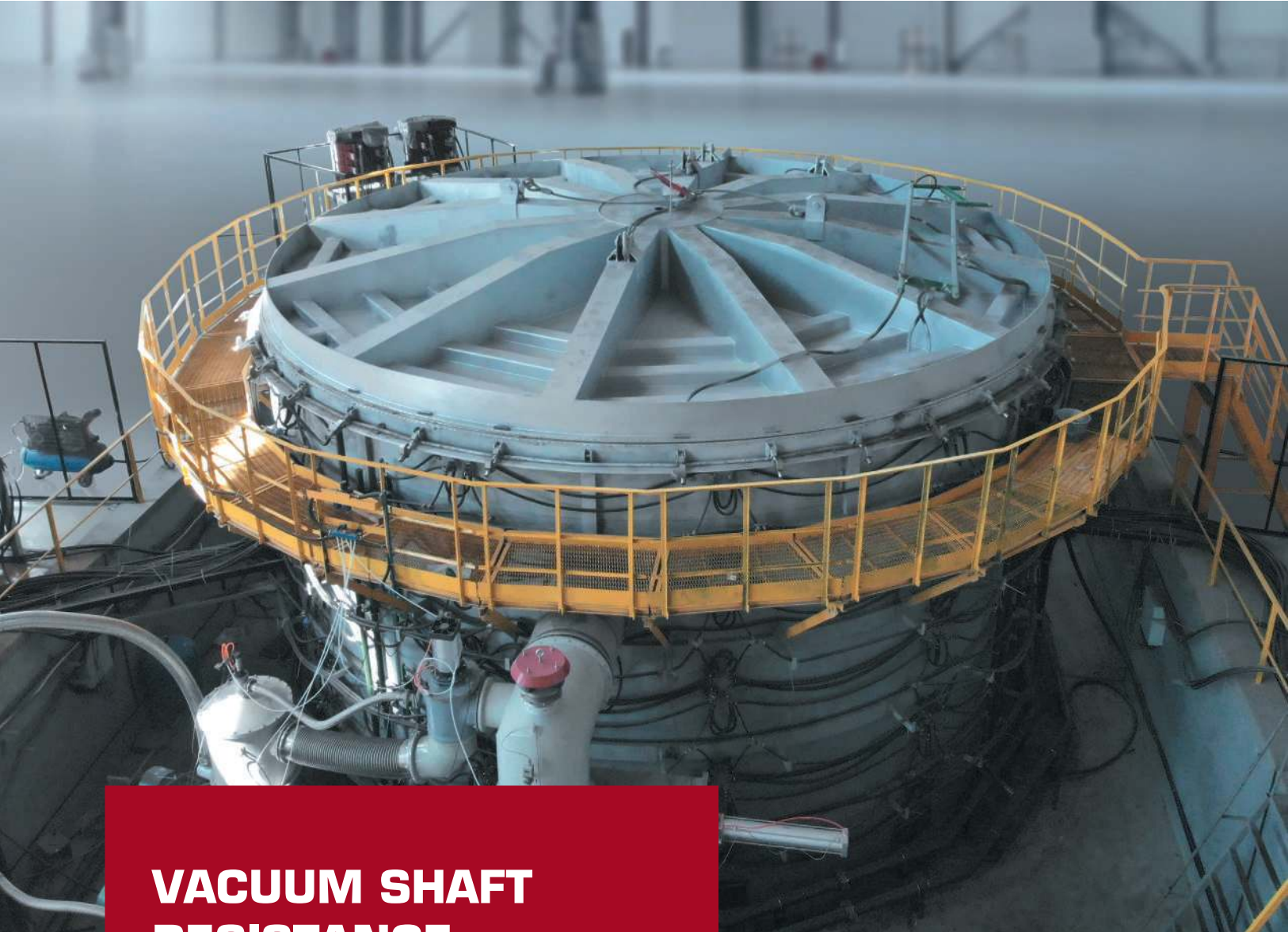

## VACUUM SHAFT RESISTANCE FURNACE

**The furnace** is designed for vacuum annealing of large welded constructions from martensite and austenite metals to relieve internal stresses.

Production of critical welded construction, especially those for vacuum chambers, creates stress in the inner structure of materials. In the long run this could result in destruction of a unit; in case of a vacuum chamber it might lead to the leakage, and as consequence in complete loss of its operability.

In order to solve this issue, the "NPO "GKMP" LLC developed, manufactured and launched into production an electrical vacuum resistance shaft furnace that enables to anneal and quench constructions produced, as well as elements of vacuum chambers 6.5 m in diameter and 4 m high.

The chamber consists of a cylindric body equipped by wore zigzag-shaped nickel-chromium and refractory brick heaters, as well as of a cap equipped with ten screens from refractory metals. The chamber is divided into twelve thermal zones.

In order to measure the operating temperature inside the chamber every zone is equipped with a thermoelectrical converter (thermocouple); another converter

### Components:

- 8m in diameter vacuum chamber body with removable upper cover;
- Special high temperature lining;
- Maintenance site;
- Vacuum pumping system based on plunger pumps, roots pump and booster vapor oil pumps;
- Pneumatic system;
- Electric heaters;
- Water cooling system;
- Control and supply system of the facility.

is installed on the cover to perform measurement in the center.

Vacuum system includes two pumping lines, polarly opposite to each other with respect to the furnace. The composition of the unit includes: booster vapor oil pumps, backing pumps (two side vacuum roots pump and plunger vacuum pumps). In order to relieve stress from Roots pumps bypass pumping lines are used.

The main advantage of the vacuum thermal treatment is no oxides or slam, or any other contaminations on the metal surface, thus it requires no additional sandblasting or any other cleaning. Once annealing is completed, the ready-made item is subject to final operations.



### Technical performances:

Maximal heating temperature	Up to 1000 °C
Maximal fluctuations to maintain the set temperature in thermal zones, not to exceed limit	±10 °C
Residual pressure inside heating chamber	6,65x10 <sup>-2</sup> (5x10 <sup>-4</sup> ) Pa (mmHg)
Number of thermal zones	12 pieces
Operating water pressure of the cooling system	0,35...0,4 (3,5...4,0) MPa (kg/cm <sup>2</sup> )
Water consumption in the cooling system	30 m <sup>3</sup> /h
Operating water pressure of the cooling system	0.35...0.4 (3.5...4.0) MPa (kg/cm <sup>2</sup> )
Operating air pressure in pneumatic system	6 m <sup>3</sup> /h
Weight of the item charged in the furnace, not to exceed	20000 kg
Size of the item charged in the furnace: - Circumcircle diameter - Height	6500 mm 4000 mm
Set power, not to exceed	1,9 MW
Electric power	3φ, 380 V
Current frequency	50 Hz
Furnace operating modes	Manual/automatic
Mass of the furnace, not to exceed	265000 kg

### Overall sizes:

Furnaces without electric devices	
Length	14050 mm
Width	12500 mm
Height	6100 mm

Furnaces with electric devices	
Length	
Width	
Height	

Furnace mounting pit, no less than:	
Length	15300 mm
Width	11300 mm
Height	2400 mm



## TOKAMAK 15-MD

**Tokamak** is an experimental facility to create and study controlled thermonuclear fusion. Plasma parameters: large radius 1.48 m, small radius 0.67 m, plasma current 2MA, toroidal magnetic field on the plasma axis 2T.

The facility is equipped with additional plasma heating system 15-20 MW power, that enables to reach the temperature of over 5-9 keV at electron concentration  $\sim 10^{20} \text{ m}^{-3}$ . The expected discharge length is about 30 s.

The Tokamak vacuum chamber is designed to generate plasma with thermonuclear parameters, as well as to locate items inside the chamber and diagnostics.

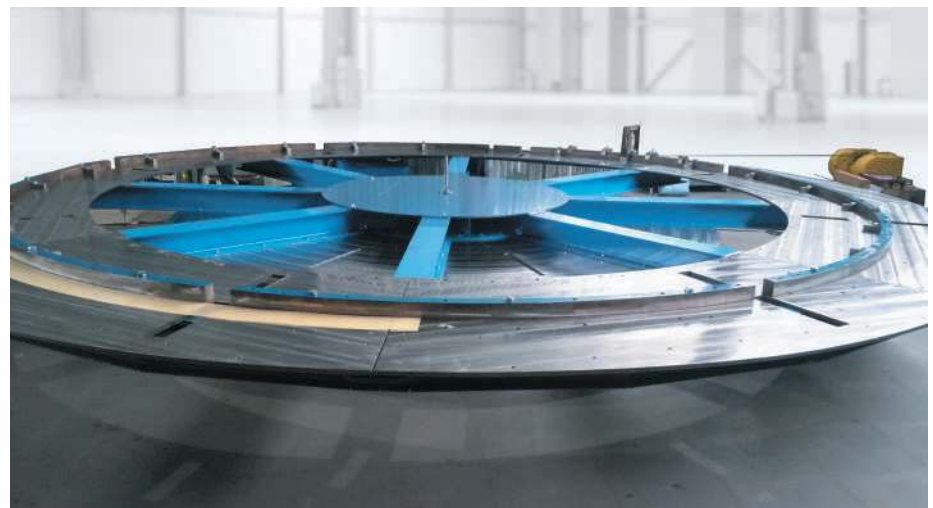



### Technical characteristics:

Internal size of the chamber in vertical direction	3.39 m
Chamber wall thickness	5...8 mm
Chamber capacity	~47 m <sup>3</sup>
Ultimate background pressure	10 <sup>-5</sup> Pa
Wall covering material	Graphite FP497
Vacuum chamber material	Stainless steel 321
Large tor radius R, m	1.48
Aspect ratio	2.2
Plasma current IP, MA	2.0
Elongation, k	1.9
Plasma configuration	SN, DN
Triangularity	0.3 – 0.4
Impulse length, s	10 (30)
Toroidal magnetic field, T	2
Magnetic flow margin in central solenoid, Wb	6
System for additional heating and maintaining of plasma, MW	15 – 20
Neutral injection power, MW	6 (3 injectors, 2 MW/75 keV)
Electronic-cyclotron resonance heating power, MW	7 (7 gyrotron, each 1.0 – 1.5 MW, f=110 – 120 GHz with a heating option either within the 2 <sup>nd</sup> harmonic, or in Bernstein mode)
Ion cyclotron resonance heating power, MW	6 (3 antennas, 2MW each, including possible current maintenance by helicons)
Galvanic heating power and current maintenance, MW	4 (f=2.45 GHz)

The magnetic system is designed to ensure and maintain the hot plasma in divertor configuration. Magnetic coils are made of silver-containing copper wire with rectangular cross-section and through-hole drilling for cold water supply. All conductors are wrapped in special vacuum sintered insulation and located in steel hard bodies.



Circular control coils have the following sizes: the internal diameter is from 5040 mm to 6322 mm, the outer diameter is from 5170 mm to 6640 mm, the height is from 210 mm to 277 mm; the mass of coils is from 4050 to 6950 kg.

16 pieces of toroidal field coils are located around the Tokamak vacuum chamber and create a radial magnetic field. The coil is 4764 mm high, 2920 wide, 285 mm deep and 7500 kg mass.

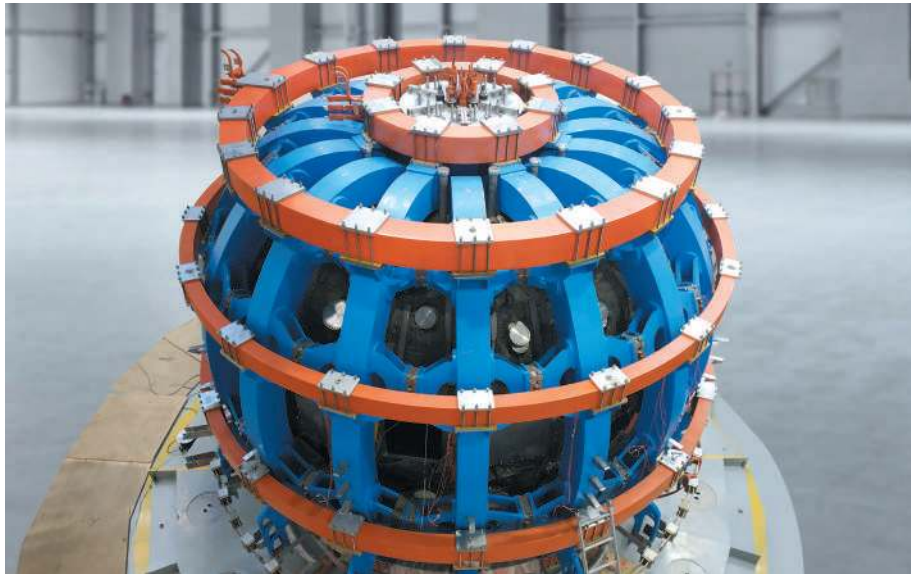
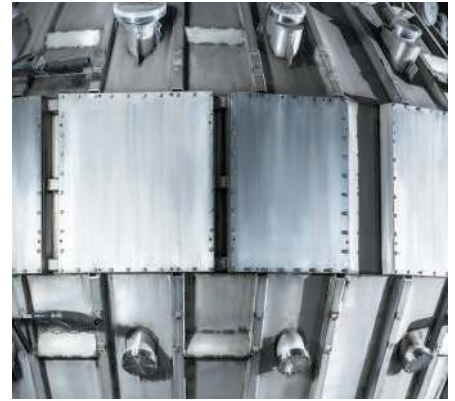

An important role in the «NPO «GKMP» development strategy is given to the cooperation with the leading think-tanks.



M. Mishustin (to the left) and M. Kovalchuk (to the right) at the Tokamak launch ceremony at the Kurchatov Research institute. Photo by Kurchatov Research institute



Photo by Kurchatov Research institute

Toroidal facility for magnetic plasma maintenance T-15 was assembled at the Kurchatov Research institute in the late 80s. In 20121 the reactor N-15 was temporary out of use due to the scheduled comprehensive upgrade activities. In 2013 the “NPO “GKMP” set to manufacture some parts of the reactor magnetic system of Tokamak-15MD, and later engaged itself in manufacture of all elements of this facility. The ever-growing energy needs were supposed to be met by the new electric power supply system. The thorough reconstruction of the existing facility that assumed all key systems to be replaced was carried out at the “NPO “GKMP” LLC production site in Bryansk. The upgrade involved creation of a brand-new electromagnetic system and vacuum chamber, as well as a new powerful electric supply system, i.e. completely new Tokamak had to be manufactured.

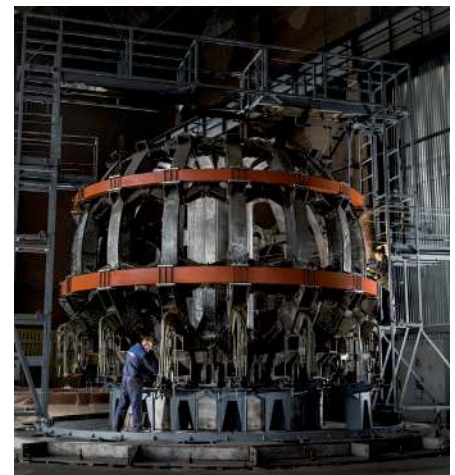

© Photo by the Kurchatov Research institute

The GKMP managed to perform the final assembly of the facility, prepared it for further transportation, dismantled the former facility and mounted a new one. While performing these activities, the company’s specialists mastered new approaches and technologies that enabled to make a big step forward. The customer in its turn received a new generation hardware with lower exploitation risks and enhanced lifetime.



# THERMAL VACUUM CHAMBER

## TVC-110

**Thermal vacuum chamber** is designed to outgas objects, manufacture honeycomb panels for spacecrafts (hereinafter referred to as S/C) and perform leak test of S/C modules.

### Technical characteristics:

Operating pressure at the given temperature of nitrogen cryogenic screens (-180 ±10)°C	<1·10 <sup>-6</sup> mmHg
Operating pressure at the given temperature of nitrogen cryogenic screens +20 °C	<1·10 <sup>-5</sup> mmHg
Temperature of cryogenic screens	-180 ±10 °C
Total leakage	Not to exceed 5 l·μ mmHg/sec
Thermal flux density	Up to 1400 W/m <sup>2</sup>
Continuous run time	46 full days
Material of the vacuum chamber	12X18H10T
Internal dimensions of the vacuum chamber:	width 4000 mm length 8100 mm height 4500 mm





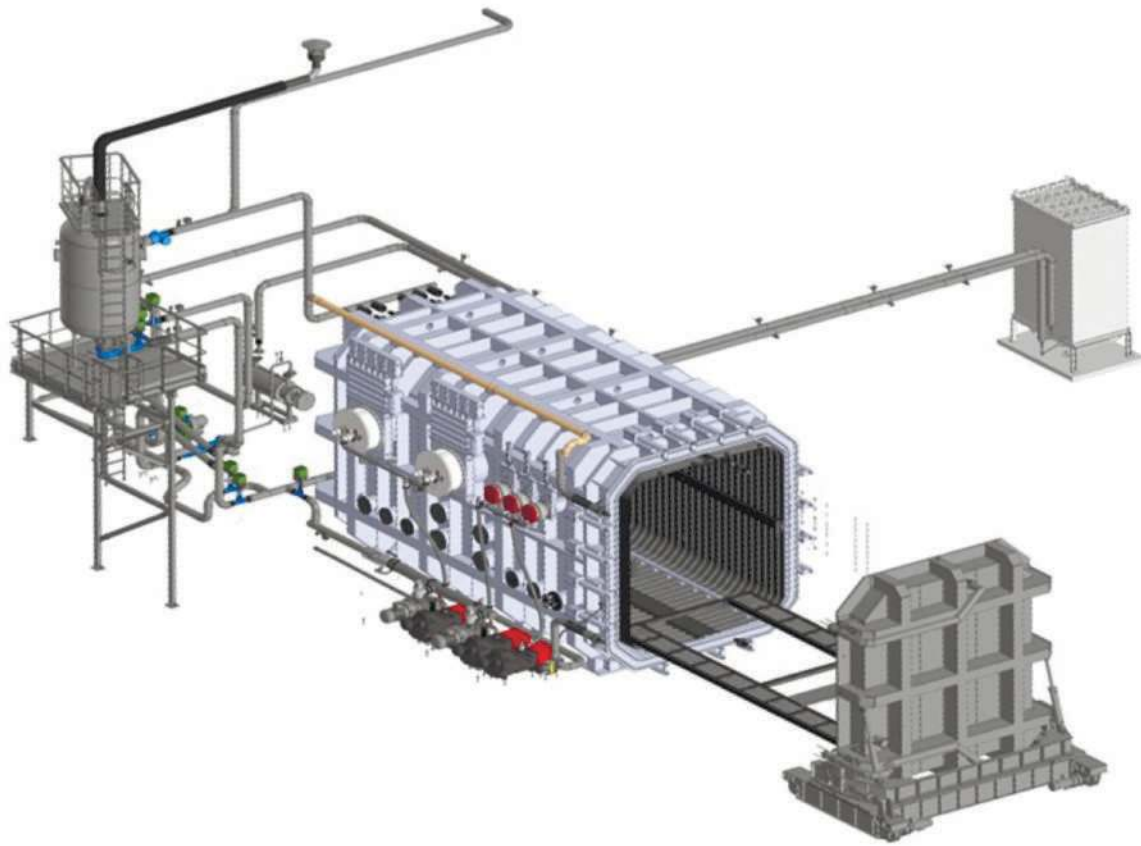

**Components:**

- Horizontal vacuum chamber for outgassing;
- Cover transfer device;
- Cover transfer control device;
- Vacuum pumping system;
- Depressurization system;
- Illumination system for scheduled maintenance;
- Technological table with the jig;
- Thermal flux imitator;
- Technological jig;
- Leak control system.



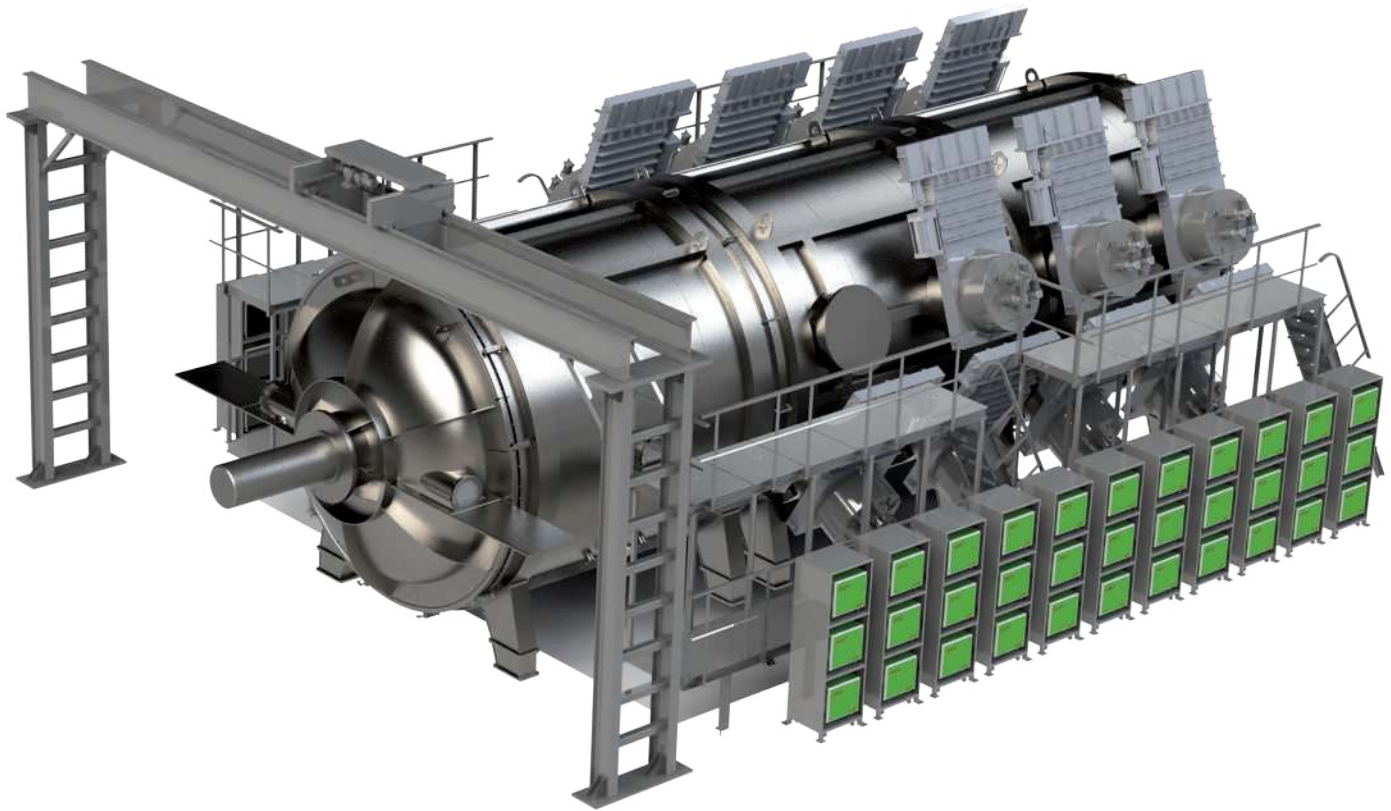

## VACUUM THERMAL EQUIPMENT FOR TESTING POWERFUL PULSED HYDROGEN PLASMA THRUSTERS

### Technical characteristics:

Internal diameter of the vacuum chamber	4 000 mm
The length of cylindric part of the vacuum chamber	12 000 mm
The power of EP thrusters under test	300-900 kW
Maximal flow rate of hydrogen	60 mg/s
Ultimate residual pressure	$10^{-5}$ mmHg
Vacuum system	Completely oil-free pumping
Duration of test	At least 20 min at ultimate power

The chamber is designed for on-ground firing test of high-power electric thrusters using hydrogen as propellant.

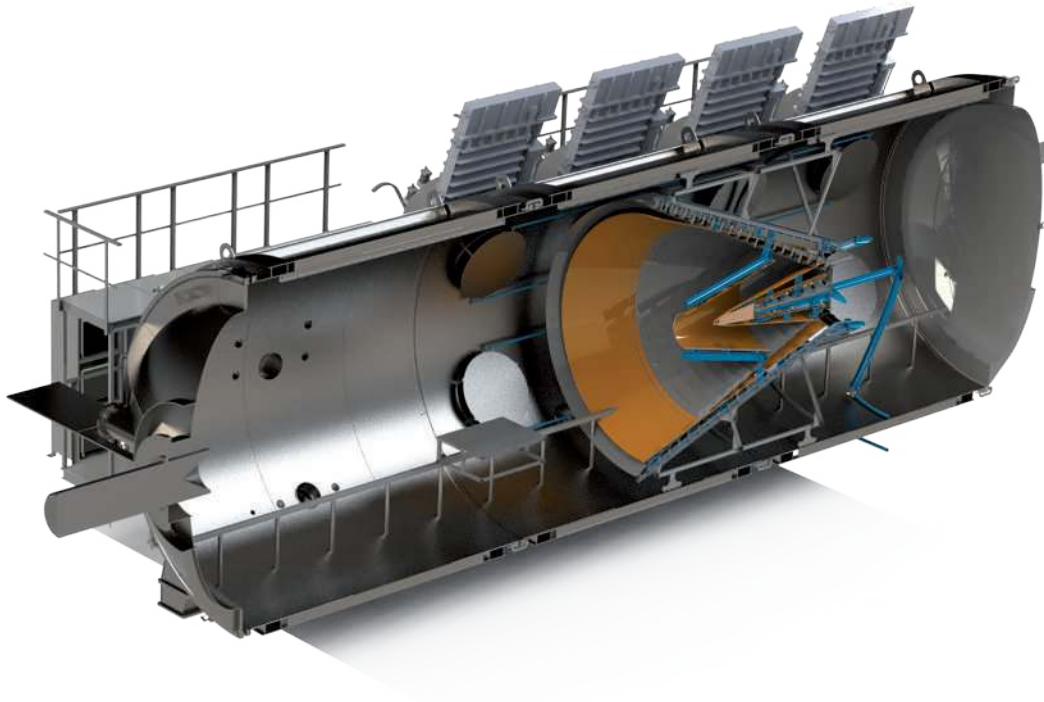

**Components:**

- Vacuum chamber;
- Plasma flow receiver;
- Thermal protection screen;
- Backing system;
- The main system for high-vacuum pumping based on specialized cryogenic pumps;
- Internal sliding desk to mount diagnostic elements;
- Tools for external optical diagnostic instruments;
- Control system.



Photo made at ITER production site  
Archive photo

## ITER PORT PLUG TEST FACILITY

In 2020 the company was awarded with a contract to design an operational project and set up experimental production of vacuum facility components to test lower and equatorial port plug (Port Plug Test Facility – PPTF).

The customer of the project is the state corporation “Rosatom”, the “ITER project center” – Russian agency ITER; the end user is the International organization ITER.



The General Director of the “NPO “GKMP” LLC Nikolay Inutin emphasized that requirements imposed on production of subsystems of the vacuum facility are rather challenging but still, the creation of such systems lies completely within the company’s expertise; this project is considered by the team as a token of trust to the reliability and workmanship of the vacuum hardware produced.

**The ITER** (International Thermonuclear experimental reactor) – an international experimental thermonuclear reactor that is under construction in France, Provence.

Apart from Russia, the ITER incorporates participants like the EU, the USA, Japan, South Korea, China and India.



Photo made at ITER production site. Archive photo



Photo made at ITER production site. Archive photo



Photo made at ITER production site. Archive photo



Photo made at ITER production site. Archive photo

This is the first large-scale project aimed at demonstrating the feasibility to use controlled thermonuclear reaction to obtain energy at industrial scale. The launch and the first experiments of the reactor are scheduled in 2025.



## CRYOGENIC VACUUM FACILITY VU-180

**VU-180** is intended to test items in simulated space environment. The chamber is of modular design and enables to adjust the required operating volume.

The cryogenic vacuum facility VU-180 is designed for cryogenic vacuum test to check quality and reliability of mechanisms, parts and nodes, as well those of electronic devices and components in simulated space environment with possible operational control of an item. The maximum duration of test is 20 days.

Modular design of the vacuum chamber allows to change the required volume by mounting/dismounting ring-shaped sections (inserts) at one's own directly at the Customer's premises.

### **Configuration:**

- Modular vacuum chamber;
- Internal technological table;
- Lighting system at maintenance;
- Vacuum pumping system;
- Cryogenic pumps;
- Liquid nitrogen supply system;
- Parameter measurement system;
- Control system.

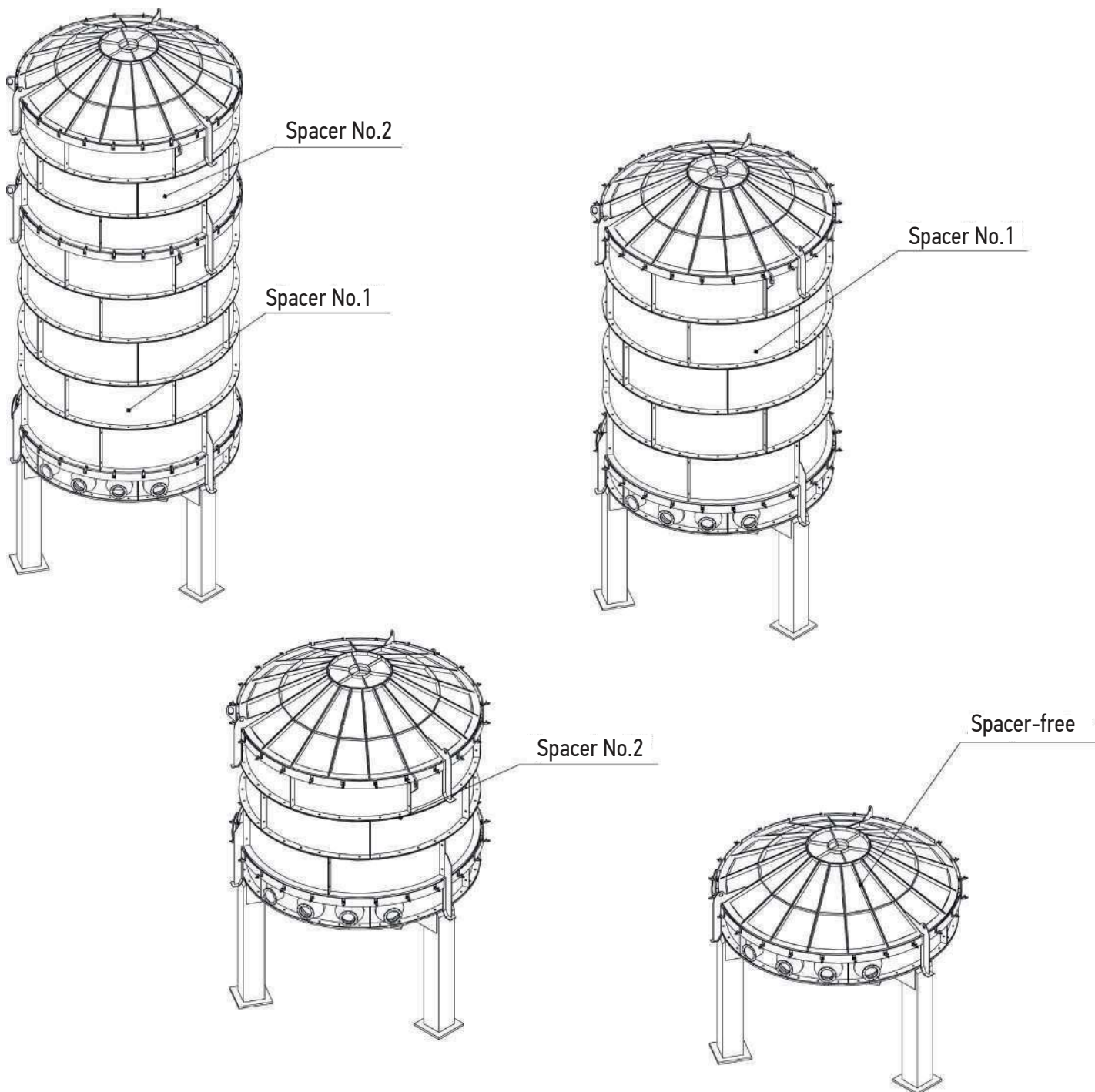

**Technical characteristics:**

Operating pressure	1.30 x 10 <sup>-3</sup> Pa (1 x 10 <sup>-5</sup> mmHg)
Ultimate pressure in chamber	5 x 10 <sup>-6</sup> mmHg
Total leakage of the vacuum chamber without test subject, not to exceed	15 l/μmHg
Average operating temperature inside the vacuum chamber	-190 ± 5°C
Diameter of internal technological table	4300 mm
Maximal load exposed om internal technological table	2500 kg

**Overall sizes:**

Outer diameter per primary structure, not to exceed	5540 mm
Internal diameter per shell	5200 mm
Height of cylindrical part of the stationary segment	800 mm
Height of cylindrical part of the spacer No.1	6700 mm
Height of cylindrical part of the spacer No.2	3300 mm
Height of chamber when assembled, not to exceed	13100 mm

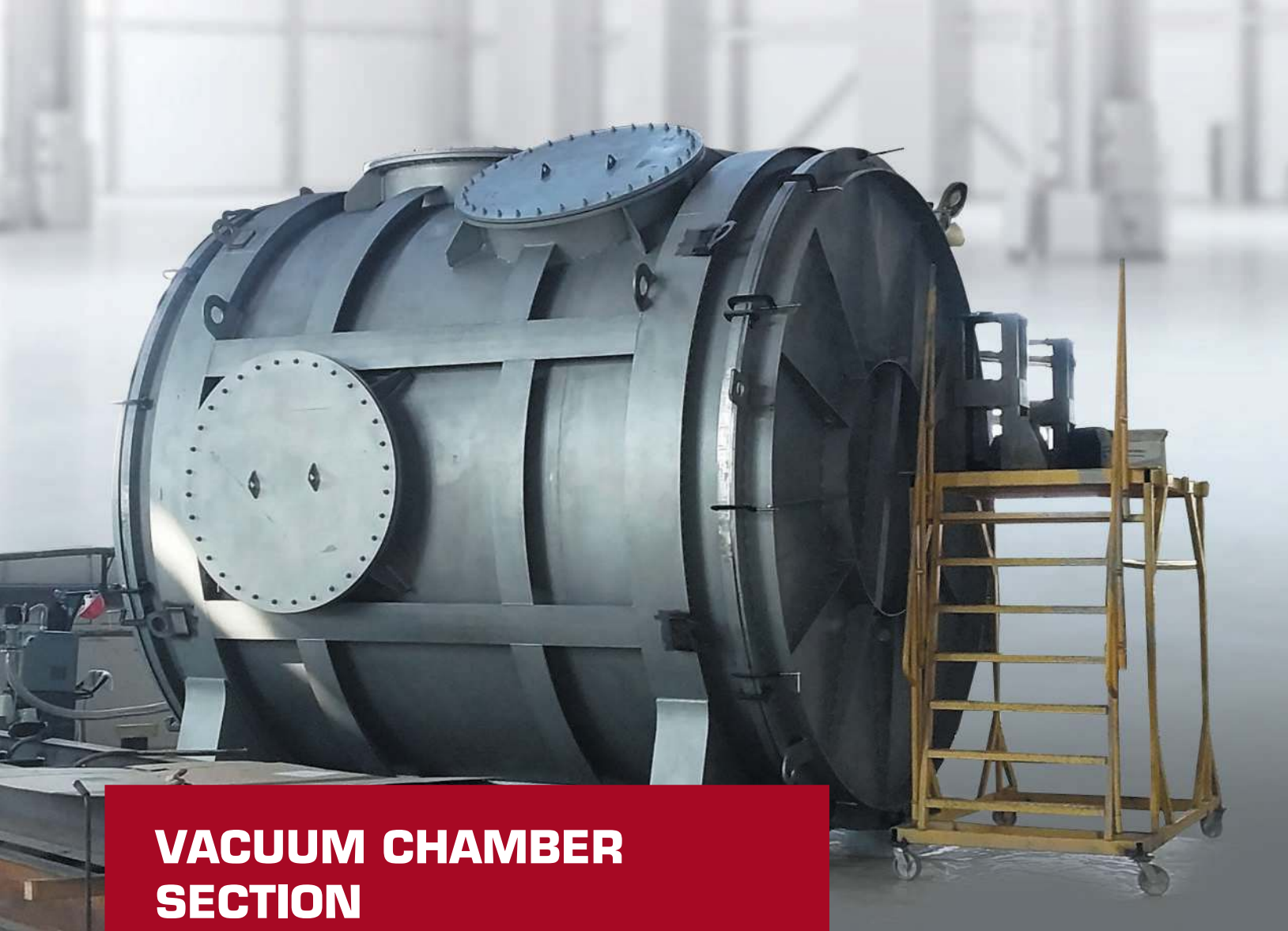

## VACUUM CHAMBER SECTION

**Vacuum chamber section** is designed to expand the existing test chamber. The section is made of stainless steel has required reinforcement beams, the internal diameter is 3800 mm, the length is 3870 mm.



The chamber is equipped with five flanges DU1250 to connect sliding shutter with cryogenic vacuum pump.



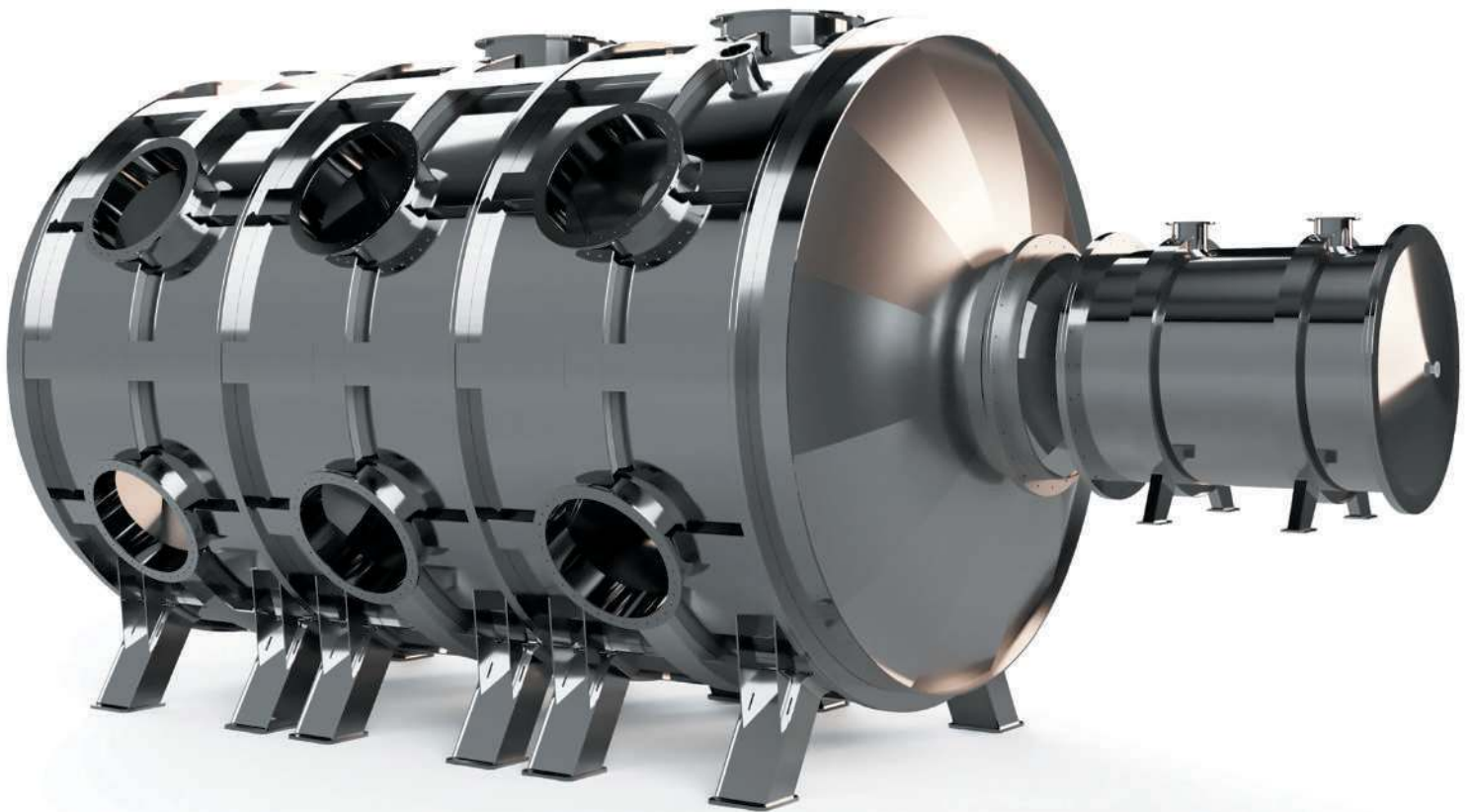

## STATIONARY PLASMA THRUSTER TEST FACILITY FOR LPSC (INDIA)

The bench is designed for firing test of high-power stationary plasma thrusters designed and manufactured by LPSC, India.

### Technical characteristics:

Main vacuum chamber	6 m
Main chamber length	9 m
Forechamber diameter	2 m
Forechamber length	2.5 m
Statistic vacuum	No less than $1 \times 10^{-6}$ mbar
Dynamic vacuum	No less than $2 \times 10^{-5}$ mbar
Xenon flowrate	20 mg/s
Power of SPTs under test	20 kW
Xenon flowrate after upgrade	Up to 60 mg/s
Power of SPTs under test after upgrade	Up to 60-80 kW

### Component:

- Main vacuum chamber;
- Forechamber for thruster installation;
- Carbonic refractory facing;
- Cooling system;
- Plasma beam trapping system ;
- Vacuum pumping system based on screw vacuum pumps, turbomolecular pump and special cryogenic vacuum pump upgraded for xenon pumping;
- Plasma parameter analytic measurement system;
- Control system.



## CARBOTHERMAL SYNTHESIS FACILITY (CSF)

This particular bench is a completely automatized facility consisting of 8 gas and vacuum push furnace designed to carry out complicated sintering and deposition processes within a single automatic transport leak proof line. The facility is capable to operate 24/7 within a year without involving any staff.

The facility consists of 8 gas and vacuum furnaces, and a transportation system between furnaces. The facility is completely sealed and equipped with two airlock chambers to load workpieces and unload items.

The “NPO “GKMP” LLC produces specific technological lines of any complexity and application, including those to implement complex and hazardous technological processes.

**Application:** any completely automated production where operator involvement is not necessary or not preferable.

Technological lines produced by the “NPO “GKMP” are in line with the international standard Industry 4.0.

### Key advantages of technological lines:

- Full implementation of a technological cycle of treatment within one close loop complex;
- Minimal interaction between operators and items treated, thus almost completely excluding human factor;
- Complete comprehensive automatization of production process;
- Resource saving, energy efficiency and safety.

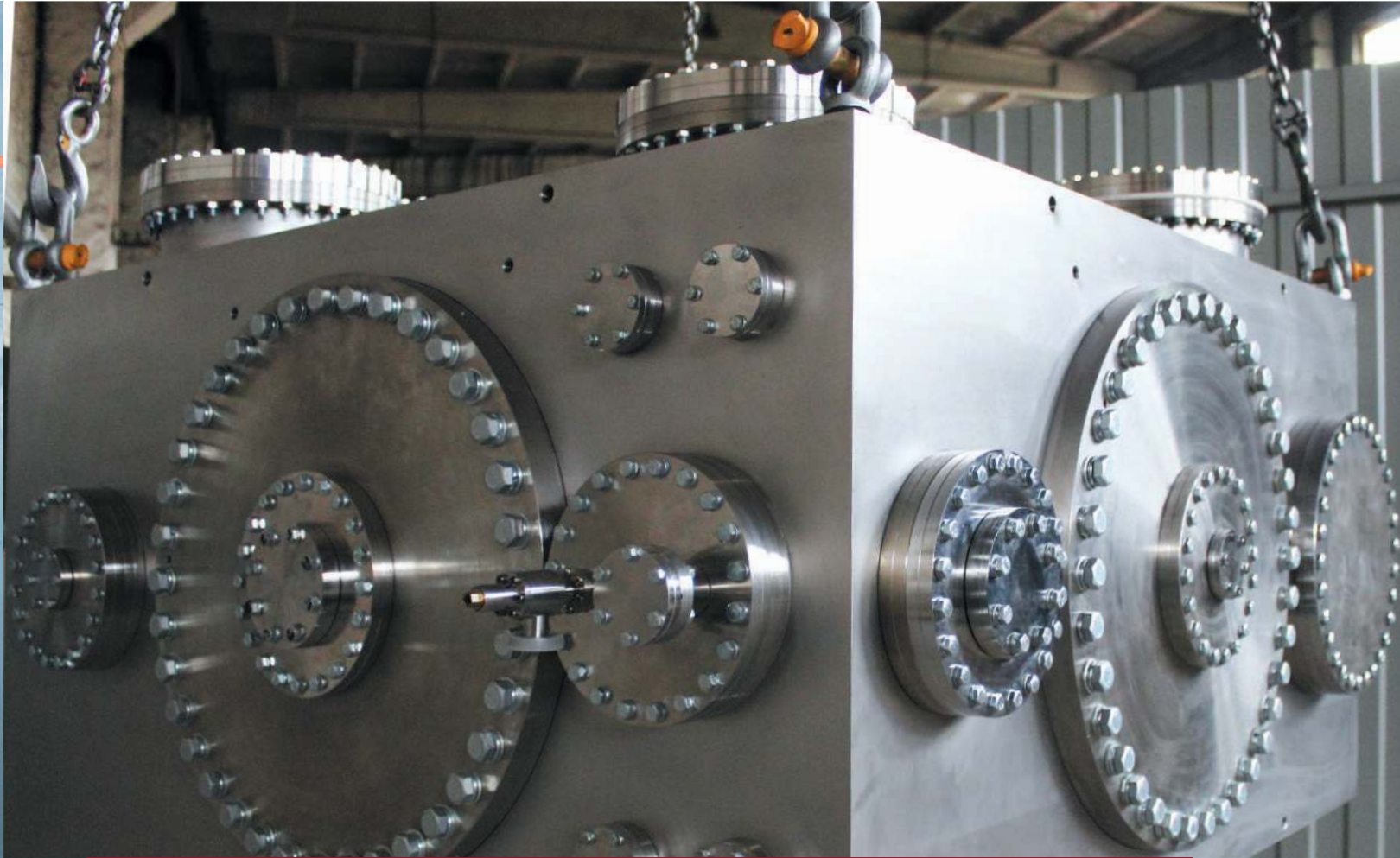

## HIGH-VACUUM ORTHOGONAL SHAPED CHAMBER FOR FUNDAMENTAL STUDIES



Vacuum chamber is designed to obtain operating vacuum equal to 10-9 mmHg ( $1.3 \cdot 10^{-7}$  Pa) and to perform researches in the field of solid-state physics.

### Technical characteristics:

Overall size	1219.2 mm x 1219.2 mm x 685.8 mm without protruding flanges
Application	High-vacuum orthogonal chamber for experiments with molecular beams
Ultimate vacuum	$8 \times 10^{-8}$ mbar
Operating temperature range	From -15 up to 150°C

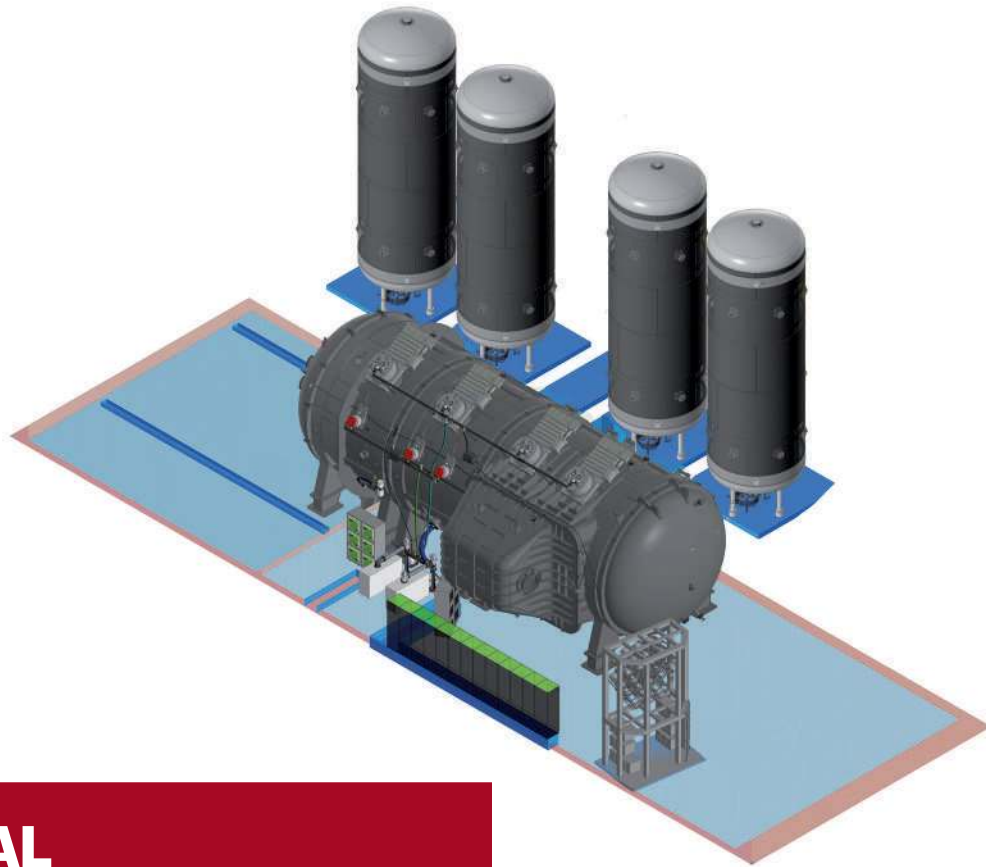

## THERMAL VACUUM TEST BENCH

**The bench** is designed to test items expected to be used in space environment to check leakage, perform thermal physical experiments, as well as to imitate solar and infrared radiation in order to study how they affect spacecrafts in conditions close to the flight ones.

The chamber is equipped with vacuum pumping system based on dry vacuum pump. The internal part of the chamber is equipped with cryogenic screens cooled down by the circulating liquid nitrogen imitating the space cold background radiation. To heat up the object placed inside the chamber, the entire surface is equipped with infrared electric heaters that simulate background thermal flux.

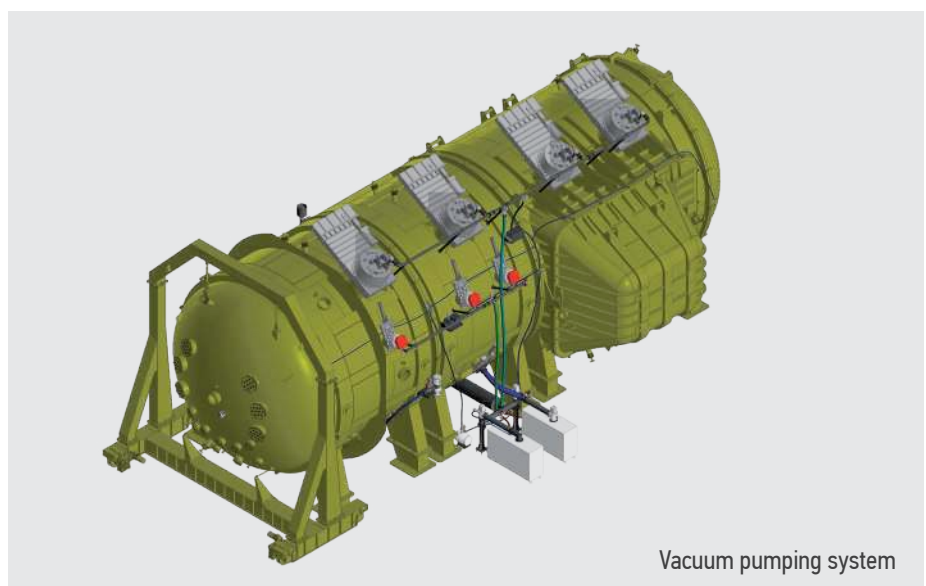

Vacuum pumping system

**Components:**

- Vacuum chamber;
- Nitrogen supply system (NST);
- Vacuum pumping system (VPS);
- Solar radiation simulation system (SRSS);
- Infrared radiation simulation system (IR);
- Automatic control system.

**Technical characteristics:**

Internal diameter of the vacuum chamber	6 000 mm
Chamber length	13 000 mm
Operating pressure of the chamber	No more than $5 \cdot 10^{-6}$ mmHg (with operating solar radiation simulator and cooled cryogenic pumps)
Temperature on cryogenic screens	$80 \pm 5$ K
Luminous spot created by the simulator	No more than $\pm 15\%$ from the average spot value
Thermal flux density	Up to 2000 W/m <sup>2</sup>

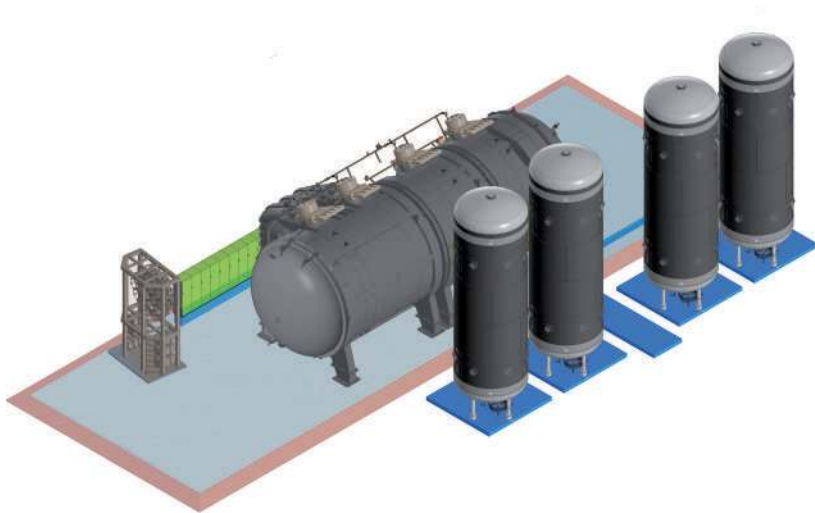

Moreover, the bench is equipped with the Solar radiation simulation system. The latter is based on the range of radiating xenon lamps, specific input and output units that ensure the perfect uniformity of the luminous spot; a mirror collimator forms the parallel light flux inside the vacuum chamber.

**Technical characteristics:**

Size of the luminous spot	2*2 m
Irradiance	Up to 2000 W/m <sup>2</sup>
Uniformity	<10%
Misalignment	+/-1.5 grad



## VACUUM AND SPECIFIC HARDWARE CONTROL SYSTEM

**Automatic control system** can operate either in automated or in manual mode. It enables to trace any performances of the system. The team fully designs the system as a “turn-key” facility.



### Components:

- Central control panel;
- Control cabinet;
- Set of cables;
- Operator's workplace;
- Software;
- Documentation.



## CRYOGENIC STORAGE FACILITIES

The process of building cryogenic storage facilities

**These facilities** are designed to store and transport liquid cryogenic agents. Cryogenic facilities and tanks are used to store, deliver and pour liquified natural gas (LNG) or technical gases (O<sub>2</sub>, N<sub>2</sub>, Ar). Such tanks can be stationary or mobile. Transportation tanks sometimes can use a jig. They are used for transportation as well for continuous storage and pouring of liquid air separation products (O<sub>2</sub>, N<sub>2</sub>, Ar). At Customer's request they can be upgraded per other design changes. Today cryogenic hardware is applied almost in any field; the application area is quite considerable: oil and gas, energy, machinery, aviation, construction, medicine etc.

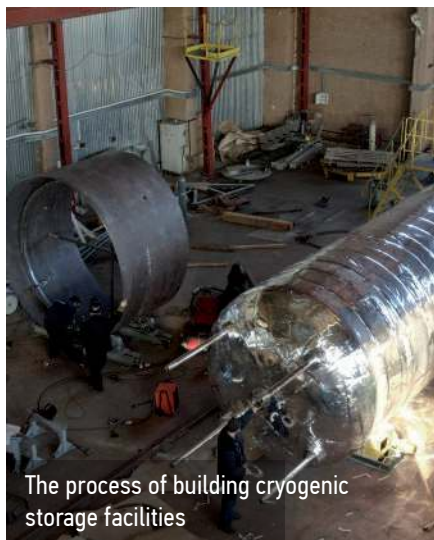

The process of building cryogenic storage facilities



Cryogenic facilities and tanks are the safest storage, transportation and output device for cryogenic agents.



# GKMP

RESEARCH & PRODUCTION  
COMPANY



## **NPO "GKMP" LLC**

Bld.2, 10 Tolbukhina street, room 2, office  
11, the Mozhaisky intracity of a federal city,  
Moscow 121596, Russia

## **Production site:**

7 Boulevard Shorsa, Bryansk 241022, Russia  
Tel. +7 (4832) 58 19 66

Email: [gkmp@gkmp32.com](mailto:gkmp@gkmp32.com)

[www.gkmp32.com](http://www.gkmp32.com)

